

Category 4, EN 954-1 PST 2

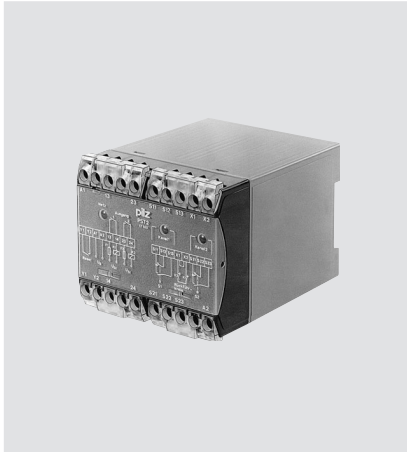

Safety gate monitor in accordance with VDE 0113-1, 11/98, EN 60204-1, 12/97 and IEC 204-1, 11/98.

Features

- Simultaneity monitoring
- Connection for start-up test button
- Automatic reset selectable

Approvals

	PST 2
	●
TÜV Wien	●
	●
	●

Technical Details	PST 2
Electrical Data	
Supply Voltage	AC: 24, 42, 110, 120, 230, 240 V DC: 24 V
Tolerance	85 ... 110 %
Power Consumption	Approx. 4 W/9 VA
Voltage and Current at the Input Circuits 1/2	24 VDC, 50 mA
Switching Capability in accordance with EN 60947-4-1, 02/01	AC1: 240 V/4,5 A/1100 VA DC1: 24 V/4,5 A/110 W
EN 60947-5-1, 11/97 (DC13: 6 cycles/min.)	AC15: 230 V/4 A; DC13: 24 V/3A
Output Contacts	2 safety contacts (N/O)
Contact Fuse Protection (EN 60947-5-1, 08/00)	6 A quick or 4 A slow
Times	
Delay-on Energisation	Approx. 100 ms
Delay-on De-energisation	Approx. 30 ms
Recovery Time	Approx. 500 ms
Simultaneity channel 1/2	Approx. 4 s
Max. Supply Interruption before De-energisation	10 ms
Mechanical Data	
Torque Setting on Connection Terminals	1.2 Nm (screws)
Maximum Cross Section of External Conductors	2 x 2.5 mm ² Single-core or multi-core with crimp connectors
Dimensions (H x W x D)	87 x 90 x 110 mm
Weight	AC: 660 g, DC: 530 g

Description

- 90 mm, P-75 housing, DIN-Rail mounting
- Positive-guided relay outputs:
 - 2 safety contacts (N/O)
- Connections for
 - safety gate limit switch
 - external simulation button
- LEDs for power, channel 1 and channel 2
- Increase in the number of safety contacts available by connecting expander modules.

Operating Modes

- Dual-channel operation

Category 4, EN 954-1 PST 2

Internal Wiring Diagram

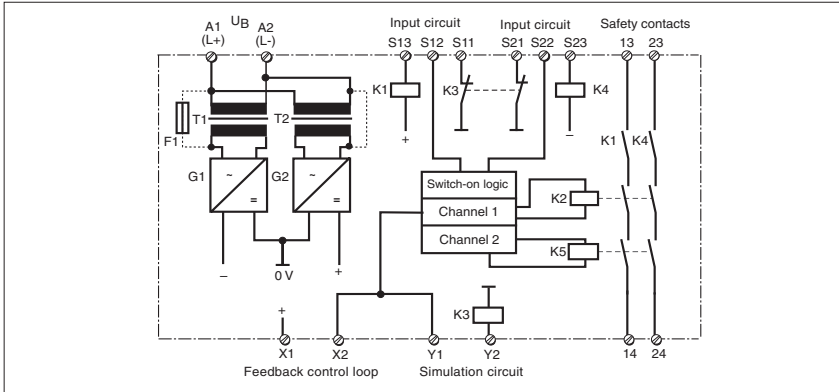

– Key

S1/S2: E-STOP or safety gate switch

S3: Simulation button

↑ Switch operated

🔒 Gate open

🔒 Gate closed

● Increase in contacts available
The number of output contacts can be increased by using expander modules or relays/contactors with positive-guided contacts.

Function Diagram

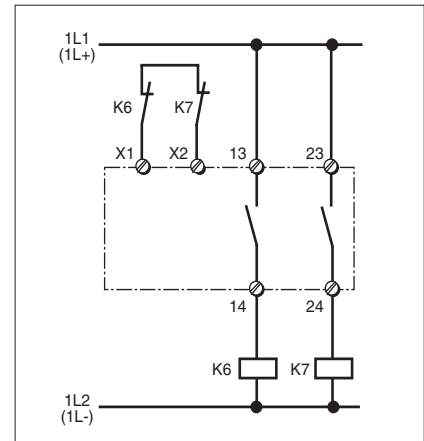
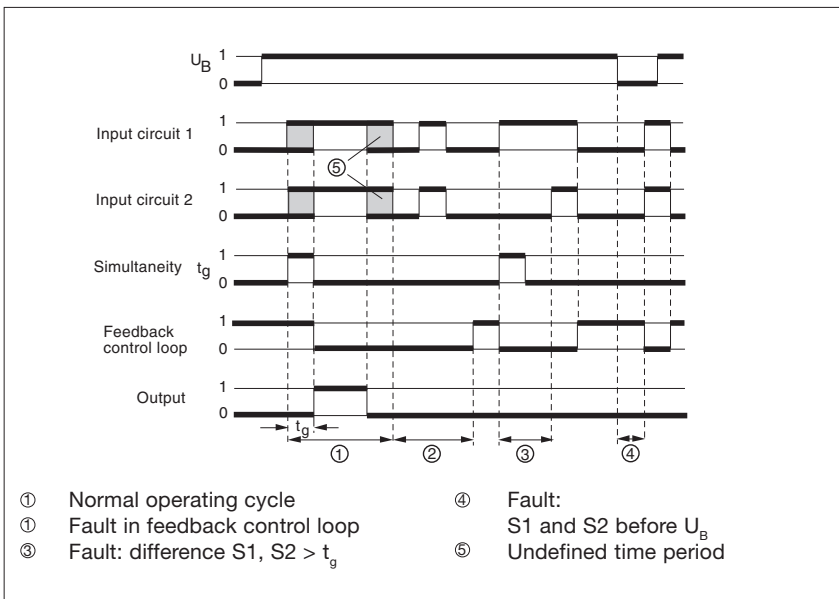

External Wiring

● Example 1
Dual-channel safety gate control with automatic reset.

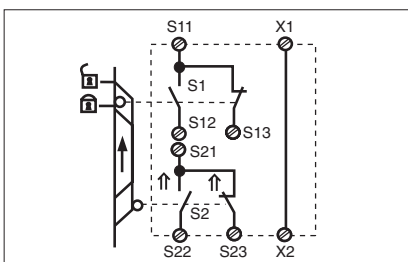

● Example 2
Dual-channel safety gate control with simulation for opening and closing the safety gate.

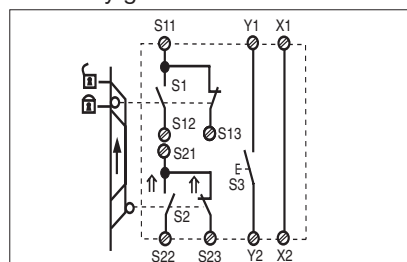

Category 4, EN 954-1 PST 2

General Technical Data

Unless stated otherwise in the technical details for the specific unit

Electrical Data

Frequency Range AC	50 ... 60 Hz
Residual Ripple DC	160 %
Contact Material	AgSnO ₂
Continuous Duty	100 %

Environmental Data

EMC	EN 50081-1, 01/92, EN 61000-6-2, 03/00
Vibration in accordance with EN 60068-2-6, 04/95	Frequency: 10 ... 55 Hz, Amplitude: 0.35 mm
Climatic Suitability	DIN IEC 60068-2-3, 12/86
Airgap Creepage	DIN VDE 0110-1, 04/97
Ambient Temperature	-10 ... +55 °C
Storage Temperature	-40 ... +85 °C

Mechanical Data

Torque Setting on Connection Terminals	0.6 Nm (screws)
Mounting Position	Any
Housing Material	Thermoplast Noryl SE 100
Protection	Mounting: IP 54 Housing: IP 40 Terminal Range: IP 20

The units were tested in accordance with the relevant standards current at the time of development.

Order References

Type	U _B	Order No.
PST 2	24 V DC	420 180
PST 2	24 V AC	420 100
PST 2	42 V AC	420 110
PST 2	110 V AC	420 130
PST 2	120 V AC	420 140
PST 2	230 V AC	420 150
PST 2	240 V AC	420 155